

**MODBUS-RTU**

*SV-iC5*



Thank you for purchase of LG Modbus-RTU Option Board!

## SAFETY PRECAUTIONS

- Always follow safety precautions to prevent accidents and potential hazards from occurring.
- Safety precautions are classified into “WARNING” and “CAUTION” in this manual.



### WARNING

Indicates a potentially hazardous situation which, if not avoided, can result in serious injury or death.



### CAUTION

Indicates a potentially hazardous situation which, if not avoided, can result in minor to moderate injury, or serious damage to the product.

- Throughout this manual we use the following two illustrations to make you aware of safety considerations:



Identifies potential hazards.

Read the message and follow the instructions carefully.



Identifies shock hazards.

Particular attention should be directed because dangerous voltage may be present.

- Keep this manual at handy for quick reference.



## CAUTION

- **Do not touch the CMOS components unless the board is grounded.**  
ESD can cause break down of CMOS components.
- **Do not change the communication cable with the inverter power is turned on.**  
Otherwise, there is a danger of connecting error and damage to the board.
- **Make sure to precisely insert the connector of inverter and option board**  
Otherwise, there is a danger of connecting error and damage to the board.
- **Check the parameter unit when setting the parameters.**  
Otherwise, there is a danger of connecting error and damage to the board.

## 1. Introduction

By using a MODBUS-RTU Option board, SV-iC5 inverter can be connected to a MODBUS-RTU network. Easy use of inverter operation, monitoring by User program and Parameter change and monitoring are available using PC.

### 1.1 Interfacing type of RTU Reference

- Allows the drive to communicate with any makers' computers.
- Allows connection of up to 31 drives by multi-drop link system.
- Ensure noise-resistant interface.

Users can use any kind of RS232-485 converters. However a converter that has built-in 'automatic RTS control' is highly recommended. The specifications of converters depend on the manufacturers. Refer to the converter manual for detailed converter specifications.

### 1.2 Before Installation

Before installation and operation, this manual should be read thoroughly. If not, it can cause personal injury or damage other equipment.

## 2. Specification

### 2.1 Performance specification

Items	Specifications
Communication method	RS485 (RS232-485 converter)
Transmission form	Bus method, Multidrop Link System
Applicable inverter	SV-iC5 series
Converter	RS232-485, Use PC with RS232 card embedded
Number of inverters	Maximum 31 drives connectable
Transmission distance	Max. 1200m (Less than 700 m recommended)

### 2.2 Hardware Specifications

Items	Specifications
Installation	Option connector on the inverter control board
Power Supply	Control B/D
	Comm. B/D
	From inverter power supply
	From inverter power supply

### 2.3 Communication Specification

Items	Specifications
Communication speed	19200/9600/4800/2400/1200 bps Selectable
Control procedure	Asynchronous communication system
Communication system	Half duplex system
Character system	Binary (8 bit)
Start/Stop bit	1 bit
Error check(CRC16)	2 byte
Parity check	None

## 3. Product Detail

### 3.1 Layout and detail

Name	Description		
Connector	Connector to inverter main PCB		
Signal connection terminal	Communication signal connection terminal	P	485 signal - high
		N	485 signal – low
		G	485 Ground

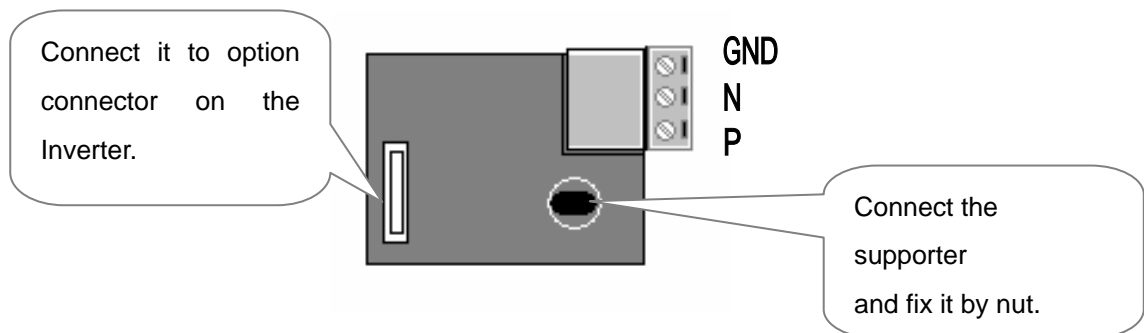

Figure 3. Layout of comm. terminal

Pin #	GND	N	P
Description	Ground	Signal	

# GND: Ground for RS 485 terminal

## 4. Installation

### 4.1 Installation of Comm. board

Connect the option board to the inverter control board using each connector on the board (See the Figure 2). Check for the position of supporter. Incorrect installation results in faulty connection of option card.

Double check the board is firmly installed to the board and then apply the inverter power.

When card installation and parameter setting are finished, turn the power off to connect the converter.

Connect the jumper for terminating resistor when option card is connected at the end of network. (see figure 3).

When ~ is done correctly, set the parameters for communication according to the below table.



**LG**



**LG Industrial Systems Co., Ltd.**

LGIS constantly endeavors to improve its product so that information in this manual is subject to change without notice.

**Visit Our Website:** <http://www.lgis.com/>

May, 2003

Parameter code	Display	Setting Value
< I - 60 >	Inverter number	1~32
< I - 61 >	Baud-rate	1200~19200 [bps]
< I - 62 >	Lost command	0~2
< I - 63 >	TimeOut (Note 1)	0.1 sec (Factory default)

Note 1) It is used for Emergency Stop when communication between inverter and master is not done properly. It is activated when communication is not made even once for the set time. It means remote controlling of inverter is not done. Set this value for safety.

Turn off the inverter power before the connection of the Converter when parameter setting is finished.

## 4.2 Installation of communication board

Follow the steps below for models SV004~008iC5.

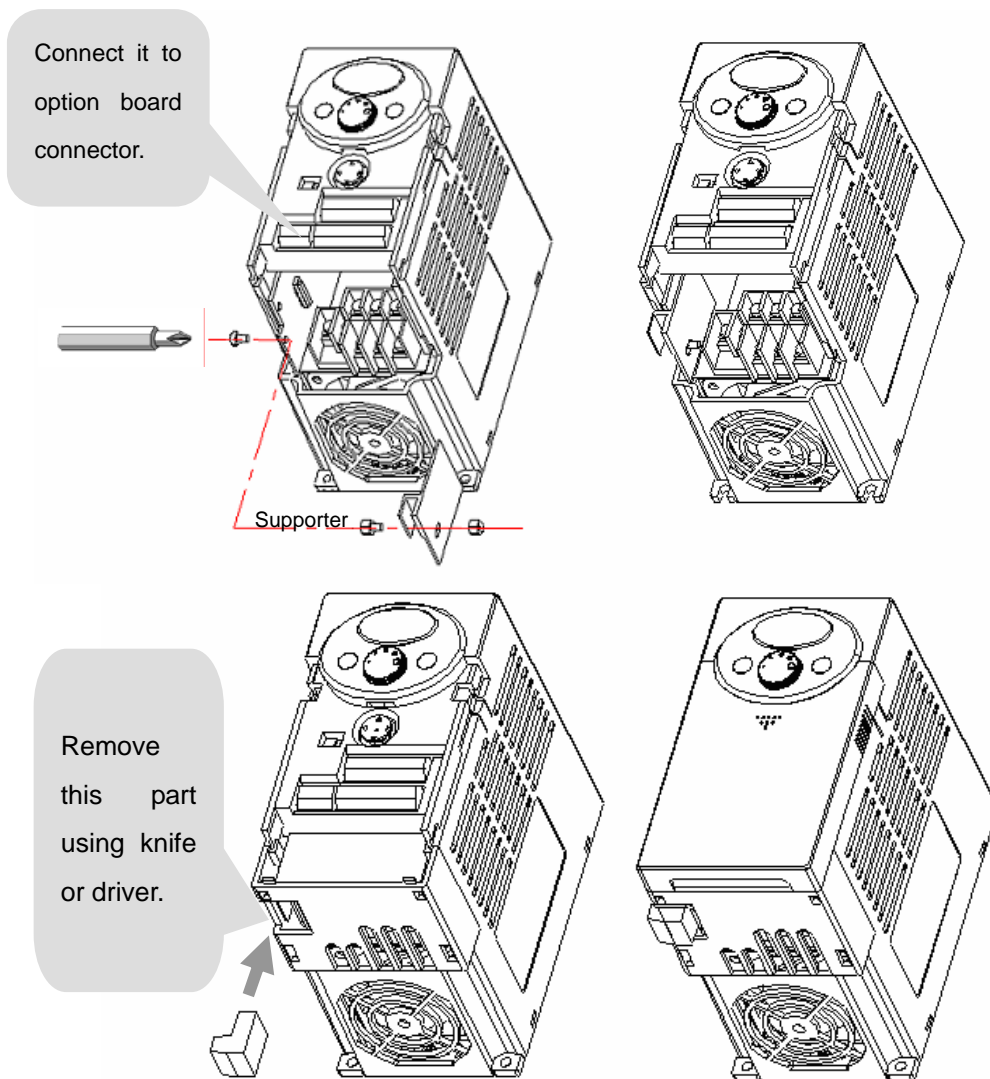
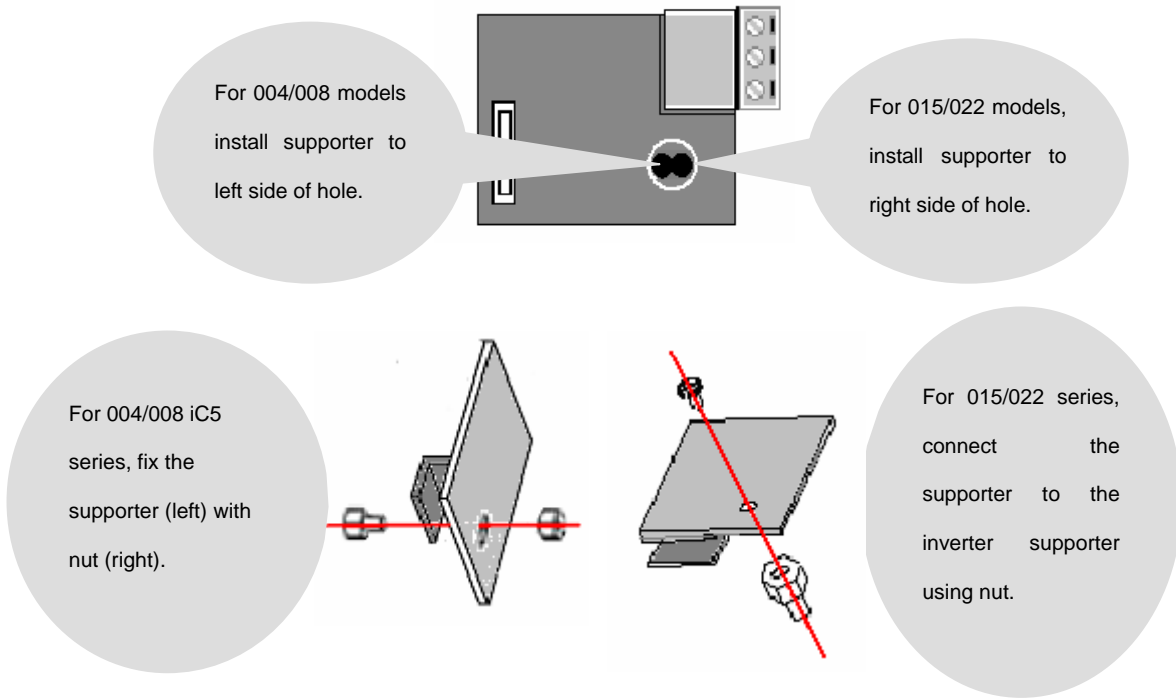
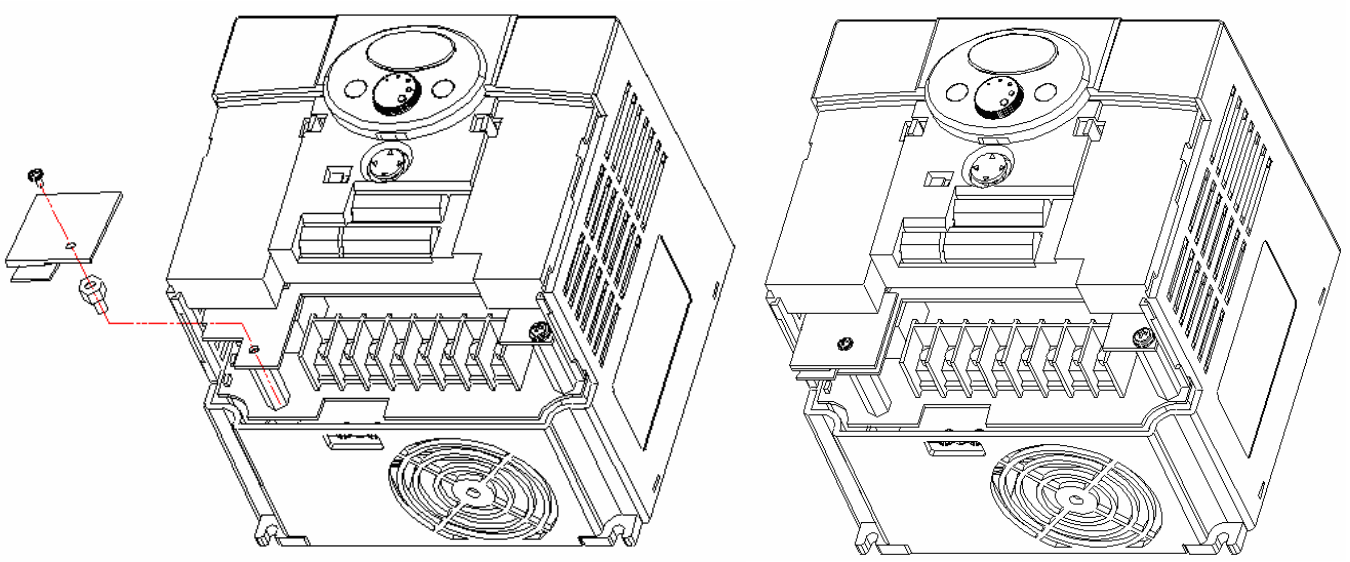

Figure 2. ModBus-RTU card installation

Fix the supporter using nut.



There are two holes on the option board for connection of option and inverter. Use left hole for models 004/008 iC5 and right for models 015/022 iC5 series.



For models SV 015/022 as shown above, loosen the bolt on the connector for Comm. Option and tighten it onto the supporter on the inverter case. Before fixing the option board, bottom cover plastic part for Comm. Option should be removed using knife or driver. The same method is used as 004/008 installation.

Connect the option board to inverter and reapply the bottom cover before tightening the supporter. Follow the opposite order when disassembling.

### 4.3 Installing RS232-485 converter

Installing method is different from makers. Refer to converter manual for installation.

### 4.4 Computer, Converter and Option board connection

#### 4.4.1 System configuration

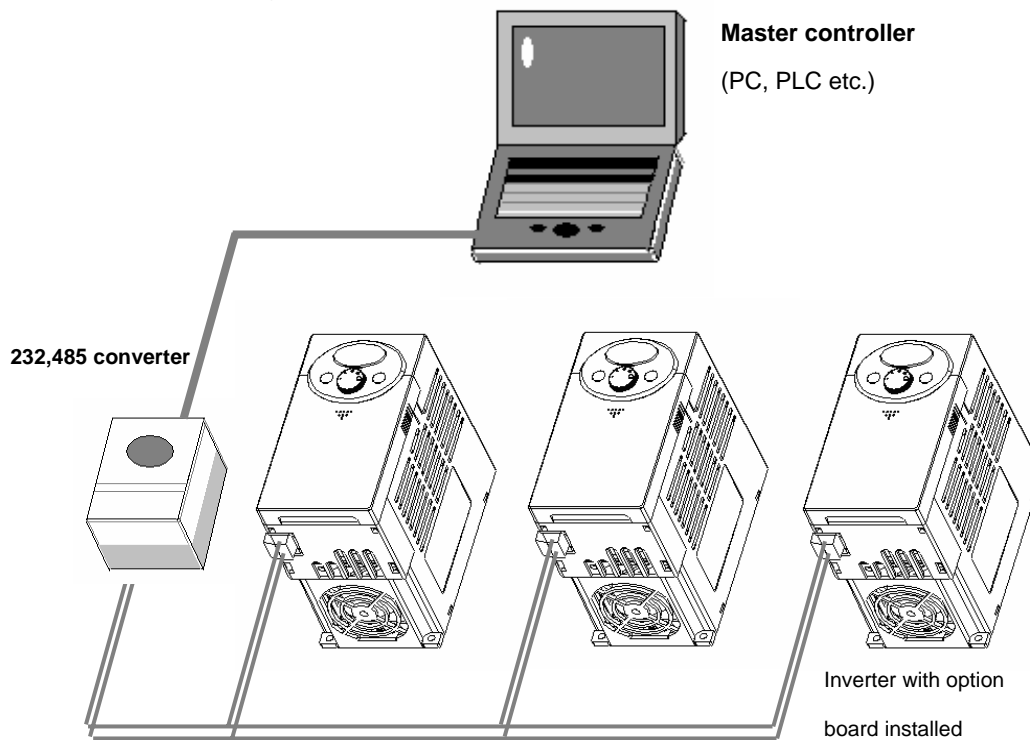

Figure 2. System configuration

# Max connectable inverters: 32

# Extension Line Length: Max 1200m (Less than 700m recommended)

## 5. Communication protocol

Use the ModBus-RTU protocol (Open).

Computer or other hosts are a Master with inverter Slaves. Inverter responds to the Read/Write request by Master.

### 5.1 Supported Function Code

Function Code	Name
0x03	Read Hold Register
0x04	Read Input Register
0x06	Preset Single Register
0x10	Preset Multiple Register

## 5.2 Exception Code

Exception Code		Name
0x01		ILLEGAL FUNCTION
0x02		ILLEGAL DATA ADDRESS
0x03		ILLEGAL DATA VALUE
0x06		SLAVE DEVICE BUSY
User define	0x14	1. Write Disable (Address 0x0004 value is 0) 2. Read Only or Not Program during Running.

## 5.3 BaudRate

1200, 2400, 4800, 9600, 19200bps settable (default: 9600bps)

## 6. Troubleshooting

### 6.1 Communication is not established

Checking point	Diagnosis
Is input power applied to converter?	Apply power to the converter.
Is the wiring of converter and PC correct?	Refer to converter manual.
Is Option card connection to the inverter incorrect?	Refer to "4. Installation".
Is Master not polling?	Verify that the Master is polling the inverter.
Is baud rage set correctly?	Refer to "4. Installation".
Is Data format of User program correct?	Revise User program (Note 2).
Is the wiring of converter and option board correct?	Refer to "4. Installation".

Note 2) User program is User-made S/W for PC.

### Parameter Code (Hex)

< Common area > Area accessible regardless of inverter models (Note 3)

#### Common area

Address	Parameter	Scale	Unit	R/W	Description
0x0000	Inverter model			R	0 : SV-iS3 1 : SV-iG 2 : SV-iV 3 : SV-iH 4 : SV-iS5 5 : SV-iV5 6 : 7 : SV-iG5 8 : SV-iC5 9 : SV-iP5
0x0001	Inverter capacity			R	0: 0.75kW, 1: 1.5kW, 2: 2.2kW -1: 0.4kW (indicated as 65535)
0x0002	Inverter input power			R	0 : 220V 1 : 440V

Common area

Address	Parameter	Scale	Unit	R/W	Description
0x0003	S/W Version			R	(Ex) 0x0100 : Version 1.00 0x0101 : Version 1.01
0x0004	Parameter Read/Write enable			R/W	0: Parameter Lock 1: Parameter Read/Write Enable
0x0005	Frequency Reference	0.01	Hz	R/W	Starting freq ~ Max freq
0x0006	Operatin command (Option)			R/W	BIT 0 : Stop (S) BIT 1 : Forward Run (F) BIT 2 : Reverse Run (R) BIT 3 : Fault reset (0->1) BIT 4 : Emergency stop BIT 5 : Not used
0x0007	Accel time	0.1	sec	R/W	See function table
0x0008	Decel time	0.1	sec	R/W	See function table
0x0009	Output current	0.1	A	R	See function table
0x000A	Output frequency	0.01	Hz	R	See function table
0x000B	Output voltage	0.1	V	R	See function table
0x000C	DC Link Voltage	0.1	V	R	See function table
0x000D	Output power	0.1	kW	R	See function table
0x000E	Status of Inverter			R	BIT 0 : Stop BIT 1 : Forward running BIT 2 : Reverse running BIT 3 : Fault (Trip) BIT 4 : Accelerating BIT 5 : Decelerating BIT 6 : Speed arrival BIT 7 : DC Braking BIT 8 : Stopping Bit 9 : Not Used BIT 10 : Brake Open (I55: 3 or 4)  BIT13: REM. R/S BIT14: REM. Freq.
0x000F	Trip information			R	BIT 0 : OCT BIT 1 : OV BIT 2 : EXT-A BIT 3 : EST BIT 4 : Option BIT 5 : GF(Ground Fault) BIT 6 : OH(Inverter overheat) BIT 7 : ETH(Motor overheat) BIT 8 : OLT(Overload trip) BIT 9 : HW-Diag BIT10: EXT-B BIT11: EEP

Common area

Address	Parameter	Scale	Unit	R/W	Description
					BIT12: FAN BIT13: PO(Phase Open) BIT14 : IOLT BIT15: LV
0x0010	Input terminal information			R	BIT 0 : P1(FX) BIT 1 : P2(RX) BIT 2 : P3(EST) BIT 3 : P4(RST) BIT 4 : P5(JOG)
0x0011	output terminal information			R	BIT 0 : Q1 (OC1) BIT 1 : 30AC
0x0012	V1	0~10V		R	0 - 0xFFC0
0x0013	V2	0~10V		R	0 - 0xFFC0
0x0014	I	0~20mA		R	0 - 0xFFC0
0x0015	RPM			R	See function table

Note 3) The changed value in Common affects the current setting but returns to the previous setting when power is cycled or inverter is reset. However, changing value is immediately reflected in other parameter groups even in the case of Reset or Power On/Off.

Note 4) S/W version in Common area is indicated in 16 bit with parameter area in 10 bit.

**DRV group**

Address		Code	Description	Factory default	Max	Min
16 Bit	10 Bit					
8100	33024	D00	Cmd. freq	0	maxFreq	0
8101	33025	D01	ACC	50	60000	0
8102	33026	D02	DEC	100	60000	0
8103	33027	D03	DRV	1	3	0
8104	33028	D04	FRQ	0	8	0
8105	33029	D05	ST 1	1000	maxFreq	0
8106	33030	D06	ST 2	2000	maxFreq	0
8107	33031	D07	ST 3	3000	maxFreq	0
8108	33032	D08	CUR	0	1	0
8109	33033	D09	RPM	0	1800	0
810A	33034	D10	DCL	0	65535	0
810B	33035	D11	USR	0	1	0
810C	33036	D12	FLT	0	1	0
810D	33037	D13	DRC	0	1	0

F group

Address		Code	Description	Factory default	Max	MinBit
16 Bit	10 Bit					
8201	33281	F1	Run Prohibit	0	2	0
8202	33282	F2	ACC Pattern	0	1	0
8203	33283	F3	DEC Pattern	0	1	0
8204	33284	F4	Stop Method	0	2	0
8208	33288	F8	DcBr freq	500	6000	startFreq
8209	33289	F9	DcBlk time	10	6000	0
820A	33290	F10	DcBr value	50	200	0
820B	33291	F11	DcBr time	10	600	0
820C	33292	F12	DcSt value	50	200	0
820D	33293	F13	DcSt time	0	600	0
820E	33294	F14	PreExTime	10	600	0
8214	33300	F20	Jog Freq	1000	maxFreq	0
8215	33301	F21	Max Freq	6000	Freq Limit High	4000
8216	33302	F22	Base Freq	6000	Freq Limit High	3000
8217	33303	F23	Start Freq	50	1000	0
8218	33304	F24	Freq Limit	0	1	0
8219	33305	F25	High Freq	6000	maxFreq	0
821A	33306	F26	Low Freq	50	maxFreq	startFreq
821B	33307	F27	Trq Boost	0	1	0
821C	33308	F28	Fwd Boost	50	150	0
821D	33309	F29	Rev Boost	50	150	0
821E	33310	F30	VF Pattern	0	2	0
821F	33311	F31	User Freq1	1500	maxFreq	0
8220	33312	F32	User Volt 1	25	100	0
8221	33313	F33	User Freq 2	3000	maxFreq	0
8222	33314	F34	User Volt 2	50	100	0
8223	33315	F35	User Freq 3	4500	maxFreq	0
8224	33316	F36	User Volt 3	75	100	0
8225	33317	F37	User Freq 4	6000	maxFreq	0
8226	33318	F38	User Volt 4	100	100	0
8227	33319	F39	Volt Perc	1000	1100	400
8228	33320	F40	Energy save	0	30	0
8232	33330	F50	ETH select	0	1	0
8233	33331	F51	ETH 1min	150	200	F52
8234	33332	F52	ETH cont	100	F51	50
8235	33333	F53	Motor type	0	1	0
8236	33334	F54	OL level	150	150	30
8237	33335	F55	OL time	100	300	0
8238	33336	F56	OLT select	1	1	0
8239	33337	F57	OLT level	180	200	30
823A	33338	F58	OLT time	600	600	0
823B	33339	F59	Stall prev.	0	7	0
823C	33340	F60	Stall level	150	150	30

H group

Address		Code	Description	Factory default	Max	Min
16 Bit	10 Bit					
8301	33537	H1	Last Fault1	0	1	0
8302	33538	H2	Last Fault2	0	1	0
8303	33539	H3	Last Fault3	0	1	0
8304	33540	H4	Last Fault4	0	1	0
8305	33541	H5	Last Fault5	0	1	0
8306	33542	H6	Fault Clear	0	1	0
8307	33543	H7	Dwell freq	500	maxFreq	startFreq
8308	33544	H8	Dwell time	0	100	0
830A	33546	H10	Jump freq	0	1	0
830B	33547	H11	jump lo 1	1000	jumpHiFreq	startFreq
830C	33548	H12	jump Hi 1	1500	maxFreq	jumpLoFreq
830D	33549	H13	jump lo 2	2000	jumpHiFreq	startFreq
830E	33550	H14	jump Hi 2	2500	maxFreq	jumpLoFreq
830F	33551	H15	jump lo 3	3000	jumpHiFreq	startFreq
8310	33552	H16	jump Hi 3	3500	maxFreq	jumpLoFreq
8311	33553	H17	Curve Time	40	100	1
8312	33554	H18	Curve Time1	40	100	1
8313	33555	H19	Trip select	0	1	0
8314	33556	H20	Power-on run	0	1	0
8315	33557	H21	RST restart	0	1	0
8316	33558	H22	Speed Search	0	15	0
8317	33559	H23	SS Sup-Curr	100	200	80
8318	33560	H24	SS P-gain	100	9999	0
8319	33561	H25	SS I-gain	1000	9999	0
831A	33562	H26	Retry number	0	10	0
831B	33563	H27	Retry delay	10	600	0
831E	33566	H30	Motor select	0	4	0
831F	33567	H31	Pole number	4	12	2
8320	33568	H32	Rated-Slip	200	1000	0
8321	33569	H33	Rated-Curr	18	2000	10
8322	33570	H34	Noload-Curr	7	200	1
8324	33572	H36	Efficiency	72	100	70
8325	33573	H37	Inertia rate	0	2	0
8327	33575	H39	Carrier freq	30	150	10
8328	33576	H40	Control Mode	0	3	0
8329	33577	H41	Auto Tune	0	1	0
832A	33578	H42	Rs	2500	5000	0
832C	33580	H44	Lsigma	2600	30000	0
832D	33581	H45	SL P-Gain	1000	32767	0
832E	33582	H46	SL I-Gain	100	32767	0
8332	33586	H50	PID F/B	0	1	0
8333	33587	H51	PID P-gain	3000	9999	0
8334	33588	H52	PID I-time	100	3200	10
8335	33589	H53	PID D-time	0	3000	0
8336	33590	H54	PID F-gain	0	9999	0

**H group**

Address		Code	Description	Factory default	Max	Min
16 Bit	10 Bit					
8337	33591	H55	PID limit	6000	maxFreq	startFreq
8346	33606	H70	Acc/Dec freq	0	1	0
8347	33607	H71	Xcel T Mode	1	2	0
8348	33608	H72	PowerOn disp	0	13	0
8349	33609	H73	User disp	0	2	0
834A	33610	H74	RPM factor	100	1000	1
834F	33615	H79	S/W Version	Refer to Product manual	100	0
8351	33617	H81	2nd Acc time	50	60000	0
8352	33618	H82	2nd Dec time	100	60000	0
8353	33619	H83	2nd BaseFreq	6000	maxFreq	3000
8354	33620	H84	2nd V/F	0	2	0
8355	33621	H85	2nd F-boost	50	150	0
8356	33622	H86	2nd R-boost	50	150	0
8357	33623	H87	2nd Stall	150	150	30
8358	33624	H88	2nd ETH 1min	150	200	50
8359	33625	H89	2nd ETH cont	100	200	50
835A	33626	H90	2nd R-Curr	18	200	1
835D	33629	H93	Para Init	0	5	0
835E	33630	H94	Password set	0	4095	0

**I group**

Address		Code	Description	Factory default	Max	Min
16 Bit	10 Bit					
8401	33793	I1	VR filter	10	9999	0
8402	33794	I2	VR volt x1	0	viXmax	0
8403	33795	I3	VR freq y1	0	maxFreq	0
8404	33796	I4	VR volt x2	1000	1000	viXmin
8405	33797	I5	VR freq y2	6000	maxFreq	0
8406	33798	I6	V1 filter	10	9999	0
8407	33799	I7	V1 volt x1	0	viXmax	0
8408	33800	I8	V1 freq y1	0	maxFreq	0
8409	33801	I9	V1 volt x2	1000	1000	viXmin
840A	33802	I10	V1 freq y2	6000	maxFreq	0
840B	33803	I11	I filter	10	9999	0
840C	33804	I12	I curr x1	400	viXmax	0
840D	33805	I13	I freq y1	0	maxFreq	0
840E	33806	I14	I curr x2	2000	2000	viXmin
840F	33807	I15	I freq y2	6000	maxFreq	0
8410	33808	I16	Wire broken	0	2	0
8414	33812	I20	P1 define	0	24	0
8415	33813	I21	P2 define	1	24	0
8416	33814	I22	P3 define	2	24	0
8417	33815	I23	P4 define	3	24	0
8418	33816	I24	P5 define	4	24	0
841B	33819	I27	Ti Filt Num	15	50	2

I group

Address		Code	Description	Factory default	Max	Min
16 Bit	10 Bit					
841E	33822	I30	ST 4	3000	maxFreq	0
841F	33823	I31	ST 5	2500	maxFreq	0
8420	33824	I32	ST 6	2000	maxFreq	0
8421	33825	I33	ST 7	1500	maxFreq	0
8422	33826	I34	Acc Time-1	30	60000	0
8423	33827	I35	Dec Time-1	30	60000	0
8424	33828	I36	Acc Time-2	40	60000	0
8425	33829	I37	Dec Time-2	40	60000	0
8426	33830	I38	Acc Time-3	50	60000	0
8427	33831	I39	Dec Time-3	50	60000	0
8428	33832	I40	Acc Time-4	60	60000	0
8429	33833	I41	Dec Time-4	60	60000	0
842A	33834	I42	Acc Time-5	70	60000	0
842B	33835	I43	Dec Time-5	70	60000	0
842C	33836	I44	Acc Time-6	80	60000	0
842D	33837	I45	Dec Time-6	80	60000	0
842E	33838	I46	Acc Time-7	90	60000	0
842F	33839	I47	Dec Time-7	90	60000	0
8432	33842	I50	FM mode	0	3	0
8433	33843	I51	FM adjust	100	200	10
8434	33844	I52	FDT freq	3000	maxFreq	0
8435	33845	I53	FDT band	1000	maxFreq	0
8436	33846	I54	Aux mode 1	12	17	0
8437	33847	I55	Aux mode 2	17	17	0
8438	33848	I56	Relay mode	2	7	0
843C	33852	I60	Inv No.	1	32	1
843D	33853	I61	Baud rate	3	4	0
843E	33854	I62	Lost command	0	2	0
843F	33855	I63	Time out	10	120	1

# MEMO

A large, empty rounded rectangular box with a thin gray border, intended for a memo. The box is centered on the page and occupies most of the vertical space below the 'MEMO' header.